

**VICINITY MAP**  
 SCALE: 1" = 1000'  
 Section 23, T4N, R45E B.M.  
 Teton County, Idaho

- LEGEND**
- = PROPERTY BOUNDARY LINE
  - = ADJACENT PROPERTY LINE
  - - - = EASEMENT LINE
  - - - = SETBACK LINE
  - - - = SECTION LINE
  - x — x — = FENCE LINE
  - = FLOWLINE DITCH (APPROXIMATE)
  - o — o — = OVERHEAD POWER
  - ◇ = FOUND REBAR WITH CAP INSCRIBED "A.W. ENGR. 2860"
  - ⊕ = FOUND SECTION CORNER REBAR
  - = FOUND SECTION CORNER PIPE
  - ▲ = SET REBAR WITH CAP INSCRIBED "NELSON ENGR 13767"

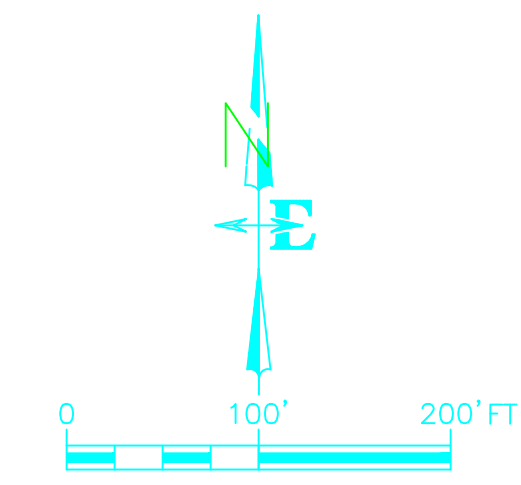

**PROJECT TOTAL:**  
 TOTAL ACRES = 20.26 ACRES  
 2 LOTS  
 LOT 1 = 1.00 ACRES  
 LOT 2 = 19.26 ACRES

WATER WILL BE INDIVIDUAL WATER SYSTEM  
 SEWER WILL BE INDIVIDUAL SEPTIC SYSTEM

TETON COUNTY ZONE:  
 IR, INDUSTRIAL/RESEARCH

BUILDING SETBACKS PER ZONE:  
 FRONT - 10'  
 SIDES - 10'  
 REAR - 10'  
 CREEK - 15'

**SURVEY NARRATIVE**

THESE PARCELS WERE CREATED USING SHORT PLAT LAND DIVISION AS OUTLINED IN TETON COUNTY CODE 9-3-3 AND ARE NOT ELIGIBLE FOR FUTURE DIVISION SUBDIVISION. USING ONE TIME ONLY LAND DIVISION OR SHORT PLAT SUBDIVISION. IF ANY OF THE LOTS ARE TO BE FURTHER DIVIDED, A SUBDIVISION PROCESS AS OUTLINED IN TETON COUNTY CODE 9-3-2 SHALL BE REQUIRED.

**CONCEPT**

**CONCEPT PLAN  
 SUBDIVISION PLAT  
 LOG CABIN LANE LLC**  
 of that Record of Survey  
 Instrument # 249918

Located In  
 NE1/4, SW1/4  
 Section 23  
 Township 4 North,  
 Range 45 East of the B.M.,  
 Teton County, Idaho

**OWNER**  
 LOG CABIN LANE LLC  
 P.O. BOX 156  
 VICTOR, IDAHO, 83455

**ENGINEER & SURVEYOR**  
 NELSON ENGINEERING  
 P.O. BOX 1599  
 JACKSON, WY 83001  
 (307) 733-2087

**NELSON  
 ENGINEERING**  
 P.O. BOX 1599, JACKSON WYOMING (307) 733-2087

SURVEYED BY: NE DRAWN: DK PROJECT NO. 24-066 DATED: 4/1/2024